

## Distribution Module Cat 5E Panels

### General

The **CommScope®** distribution module panels are available in a 24- or 48-port, straight or angled configuration. The panels exceed Category 5E standards and are designed to mount into a standard 19-inch (483mm) equipment rack. The panels accommodate either EIA-T568A or EIA-T568B wiring applications.

Ordering information is listed below:

Material ID	Description
760180000	Distribution module 24-port flat panel, 1U, Cat 5E
760180018	Distribution module 48-port flat panel, 2U, Cat 5E
760180026	Distribution module 24-port angled panel, 1U, Cat 5E
760180034	Distribution module 48-port angled panel, 2U, Cat 5E

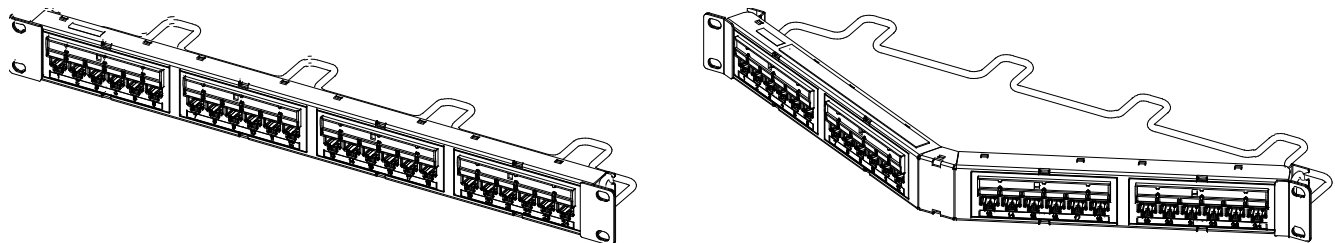

Distribution Module 24-Port Flat Panel and 24-Port Angled Panel

### How to Contact Us

- To find out more about **CommScope®** products, visit us on the web at [www.commscope.com/](http://www.commscope.com/)
- For technical assistance:
  - Within the United States, contact your local account representative or technical support at 1-800-344-0223. Outside the United States, contact your local account representative or **PartnerPRO™** Network Partner.
  - Within the United States, report any missing/damaged parts or any other issues to **CommScope** Customer Claims at 1-866-539-2795 or email to [claims@commscope.com](mailto:claims@commscope.com). Outside the United States, contact your local account representative or **PartnerPRO** Network Partner.

### Tools Required

- Phillips head screwdriver
- Cable jacket scoring tool
- D-914 punch tool with M110 blade.

## Specifications

### Wire Termination

Wire Size:

- 22-24 AWG (0.64 - 0.51 mm) Solid Copper
- 22-24 AWG (0.64 - 0.51 mm) Seven Stranded Copper

Insulation Size:

0.042 inch maximum DOD

Insulation Types:

Polyethylene, Polypropylene, and FEP

IDC Reterminations:

20 minimum

Modular Jack Mating Cycles:

750 minimum

### Environmental Data

Temperature Range:

- 40°F (-40°C) to 158°F (70°C) (Storage)
- 14°F (-10°C) to 140°F (60°C) (Operational)

Humidity:

95% Noncondensing

## Parts List

Verify parts against parts list below:

24-Port Flat Panel	Quantity			Description
	48-Port Flat Panel	24-Port Angled Panel	48-Port Angled Panel	
1	—	—	—	24-port flat panel
—	1	—	—	48-port flat panel
—	—	1	—	24-port angled panel
—	—	—	1	48-port angled panel
4	4	4	4	P12-24 x ½" mounting screws
1	2	1	2	Cable management bar
4	8	4	8	Hook-and-loop straps
1	2	1	2	Termination manager kit
4	8	4	8	Rear label, T568A wiring
1	2	1	2	Front label card (4 labels per card)
1	2	1	2	Label cover card (4 label covers per card)
1	1	1	1	Instruction sheet

## WARNING – Important Safety Instructions

When using this product, the following basic safety precautions should be followed to reduce the risk of fire, electric shock, and injury to persons:

1. Never install communications wiring in wet locations unless it is designed for wet locations.
2. Never install this product during a lightning storm. There is a remote risk of electric shock.
3. Never touch uninsulated communication wiring or terminals unless the communication circuit has been disconnected at the network interface.
4. **Caution:** All wiring that connects to this equipment must meet applicable local and national building codes and network wiring standards for communication cable.

### Step 1 – Mount Panel to Rack

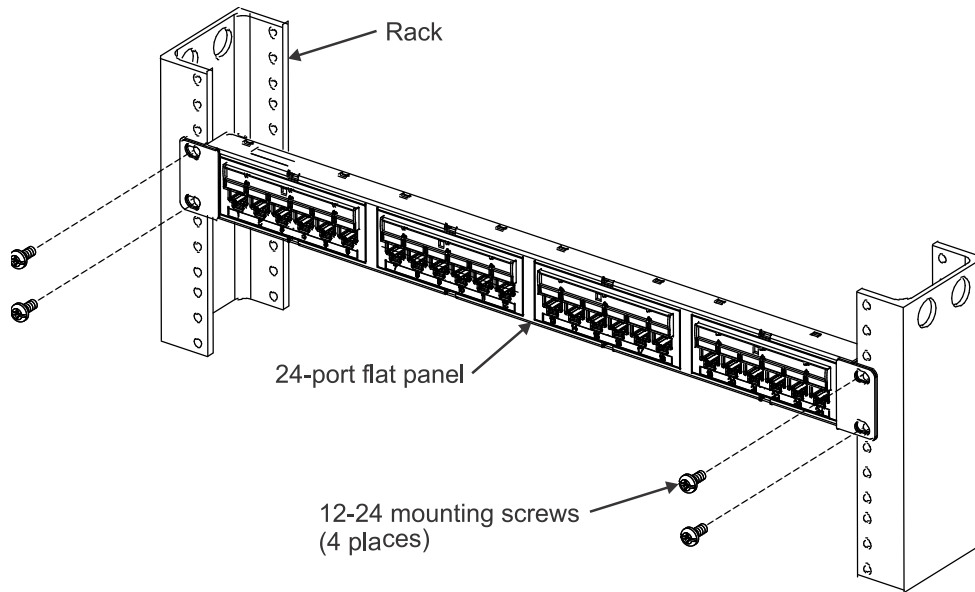

1. Mount panel to rack using the four 12-24 mounting screws provided.

### Step 2 – Terminate Conductors on Rear of Panel

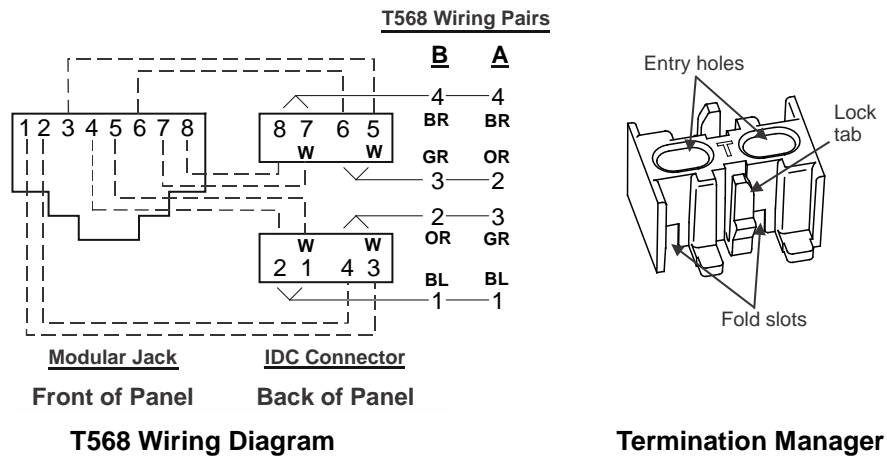

**Note:** The module comes with a T568B wiring designation label installed. If T568A wiring is desired, first remove the "B" type label and then place the "A" type label. **Do not place the "A" type label on top of the "B" type label.**

1. Prepare cable for termination. Terminate conductors on the IDC terminals per the wiring diagram shown above and utilizing the provided termination manager.
2. See pages 6 and 7 for correct procedure on using the termination manager.

## Termination of 25-Pair Cables on Panel

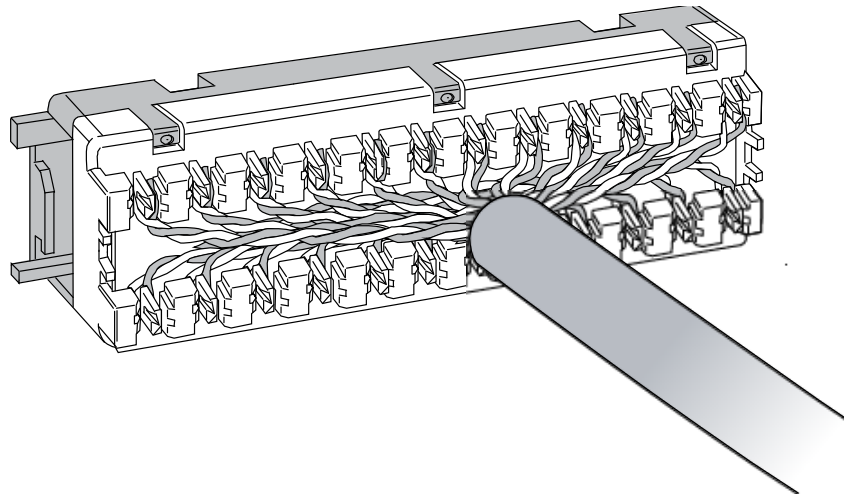

**Note:** If terminating 25-pair cables on the rear of a panel, do not use the termination managers.

1. Replace existing wiring labels on blocks with the provided 25-pair wiring labels prior to terminating the conductors. **Do not place the 25-pair labels on top of the 4-pair labels.**
2. Terminate conductors per wiring tables below.
3. Position 25-pair cable in the center of the block and between the upper and lower contacts.
4. Prepare and place all of the conductors from the center of the block outward to each end, then use a D-914 single-pair impact tool to seat and cut the conductors.

**Table A. 25-Pair Cable Terminations  
(B-Wiring Application)**

IDC No.	1	2	3	4	5	6
1	W/BL	W/GY	R/BR	BK/G	Y/O	V/BL
2	BL/W	GY/W	BR/R	G/BK	O/Y	BL/V
3	W/O	R/BL	R/GY	BK/BR	Y/G	V/O
4	O/W	BL/R	GY/R	BR/BK	G/Y	O/V
5	W/G	R/O	BK/BL	BK/GY	Y/BR	V/G
6	G/W	O/R	BL/BK	GY/BK	BR/Y	G/V
7	W/BR	R/G	BK/O	Y/BL	Y/GY	V/BR
8	BR/W	G/R	O/BK	BL/Y	GY/Y	BR/V

**Note:** Pair 25 is used for spare pair.

**Table B. 25-Pair Cable Terminations  
(A-Wiring Application)**

IDC No.	1	2	3	4	5	6
1	W/BL	W/GY	R/BR	BK/G	Y/O	V/BL
2	BL/W	GY/W	BR/R	G/BK	O/Y	BL/V
3	W/G	R/O	BK/BL	BK/GY	Y/BR	V/G
4	G/W	O/R	BL/BK	GY/BK	BR/Y	G/V
5	W/O	R/BL	R/GY	BK/BR	Y/G	V/O
6	O/W	BL/R	GY/R	BR/BK	G/Y	O/V
7	W/BR	R/G	BK/O	Y/BL	Y/GY	V/BR
8	BR/W	G/R	O/BK	BL/Y	GY/Y	BR/V

**Note:** Pair 25 is used for spare pair.

### Step 3 – Install Cable Bar and Secure Cables

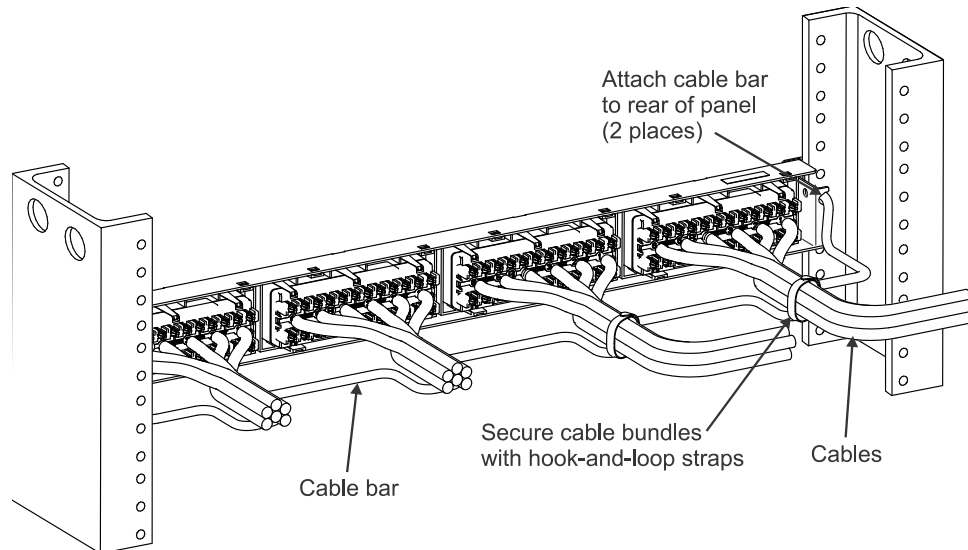

1. Once cables have been terminated, attach cable bar to rear of panel. For 48-port panels, two cable bars are provided.
2. Lay cables evenly in bends of cable bar and secure using the provided hook-and-loop straps as shown.

### Step 4 – Insert Labels and Label Covers

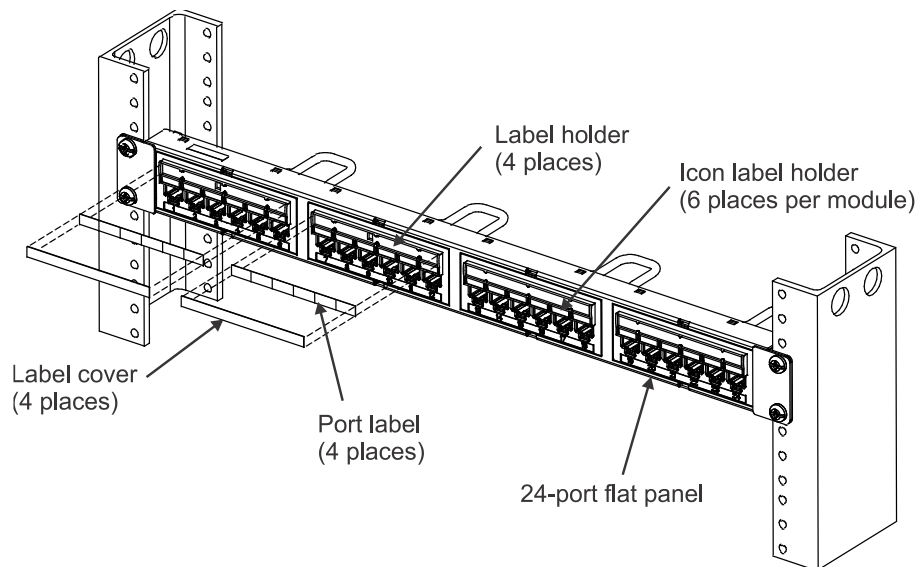

1. Print the port designations on the white label cards provided. Slide labels and label covers into the label holders from either end. Each label holder will accommodate labels up to 0.265 inches (6.7mm) high x 3.50 inches (89mm) wide.
2. Blank, voice, and data icons can be ordered separately in a wide variety of colors and placed into the pockets in the lower portion of the label holders.

**Note:** Product code M61K-XX (blank, voice, and data icons) to be ordered separately. XX denotes the color abbreviation.

3. To print a designation label, go to <http://www.commscope.com/Resources/Labeling-Templates> and scroll down to **Panels** and select the proper label template.

**Note:** Labeling website has two options for printing labels; letter size and A4 size.

## Termination Manager Instructions

The termination managers provide pair positioning, control, and strain relief features to the rear termination area of the panel. See Figure 1. Instructions for using the termination manager are listed below.

### Feed Pairs into Termination Manager (Figure 2)

1. Trim jacket back at least 3 inches (76 mm) to expose twisted-pairs.
2. Without rearrangement out of the jacket, position pairs in-line per pair colors below:

#### T568B Wiring Application (Shown)

Blue, Brown, Orange, Green

#### T568A Wiring Application

Blue, Brown, Green, Orange

3. Insert held pairs through holes on top surface of termination manager, two pairs per hole as shown. (The TOP surface is identified with a "T", which can be oriented either right side up or upside down).
4. Continue to feed pairs through termination manager until resistance is encountered at the jacket. This will usually be about 1/4 inch (6 mm) from the jacket.

### Fold Pairs Back into Slots (Figure 3)

5. Fold each pair over into adjoining slots on bottom end of termination manager. To ease item 8, it is recommended that conductor colors be viewed in the slots as listed below:

#### T568B Wiring Application (Shown)

BL/OR Pairs – Blue/Orange conductors on top

BR/GR Pairs – both White conductors on top

#### T568A Wiring Application

BL/GR Pairs – Blue/Green conductors on top

BR/OR Pairs – both White conductors on top

6. Ensure that pairs are in slots completely without being pinched over bottom end surface. **It may be necessary to add twist to align pairs with slots.**

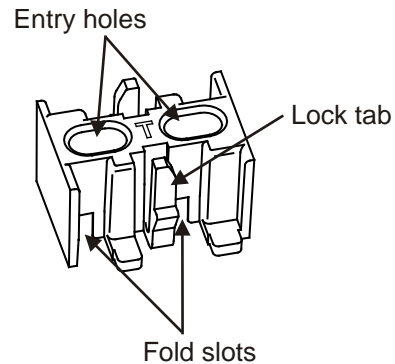

Figure 1. Termination Manager

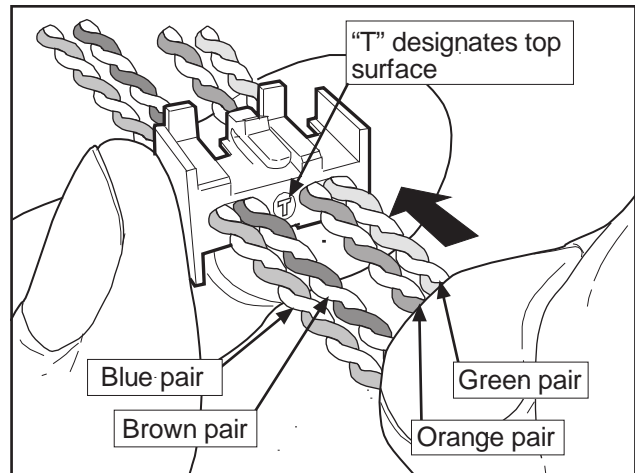

Figure 2. Feed Pairs into Termination Manager

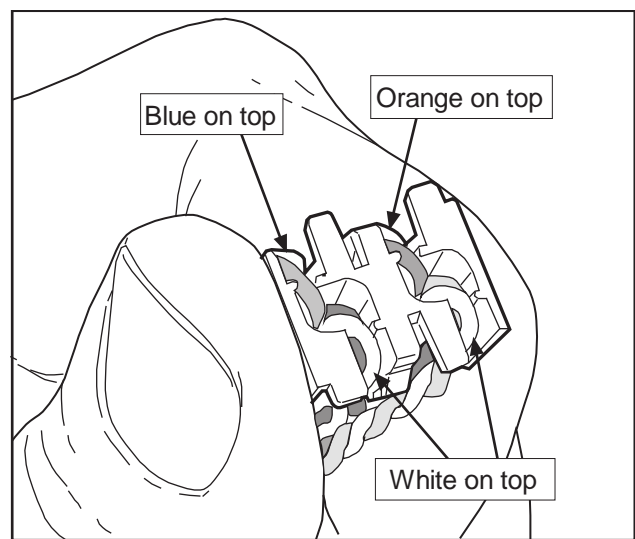

Figure 3. Fold Pairs Back into Slots

### Snap Termination Manager onto Rear Housing (Figure 4)

7. Snap assembled termination manager onto rear housing with pair colors in proper position. Push on using the termination manager, not by pushing with the cable. (Ensure that both snaps on manager fully seat into rear housing).
8. After termination manager is snapped onto rear housing, untwist individual pairs fully and line up correct color conductor and white conductor with the label on the rear housing. (The white conductor is always on the right).

### Seat Wires into IDC Terminal Slots (Figure 5)

9. Grasping each untwisted pair, push the conductors down into IDC terminal slots to seat them before punching down. Seat down into slots as far as possible. (It may be easier to use needle nose pliers to perform this task.)
10. Using the D-914 punch tool with M110 blade, punch down conductors making sure the tool is straight and that conductors fully engage in the IDC terminals. Stagger the punch-down tool up and down, so that it stays in alignment with the staggered terminal slots.

### Recommendations to Aid Assembly

1. Remove up to 5 inches (127 mm) of cable jacket to aid in seating conductors into IDC slots.
2. The termination manager should be snapped onto the rear housing immediately after the pairs have been fed and folded over into the slots. All termination managers should be installed on the panel before proceeding to seat and punch down conductors.
3. Flex cables down for easier access, then seat and punch down the entire top row of the panel.
4. Flex cables up for easier access, then seat and punch down the entire bottom row.

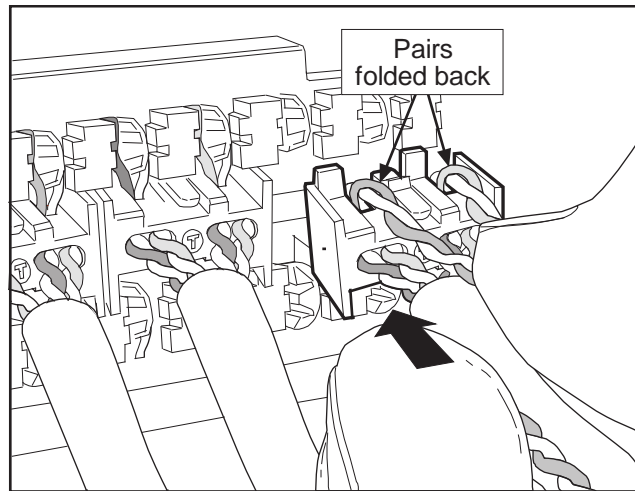

Figure 4. Snap Termination Manager onto Rear Housing

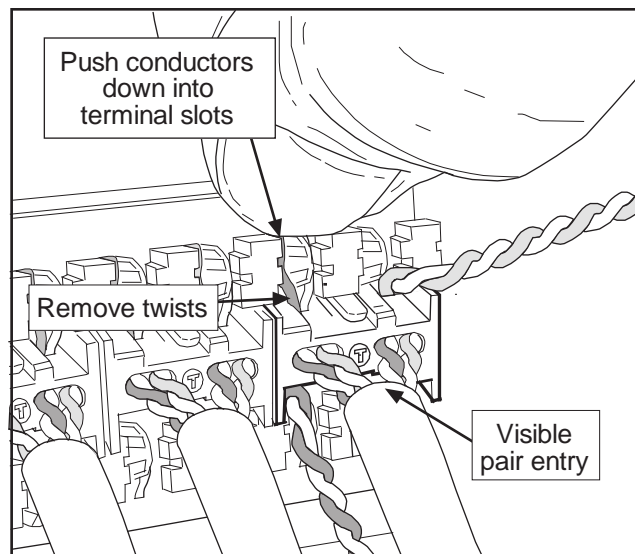

Figure 5. Seat Untwisted Pairs into IDC Terminal Slots